

HEAVY DUTY LINES

MEMBRANE, ACRYLIC AND LACQUER PAINTED COVERS - BATHROOMS AND KITCHEN CABINETS - DOORS - DOOR FRAMES AND MOULDINGS
LAMINATE FLOORING - ALUMINIUM, STEEL AND WOOD PROFILES AND PIPES - PVC PROFILE PRODUCTS ETC.

Ask for details

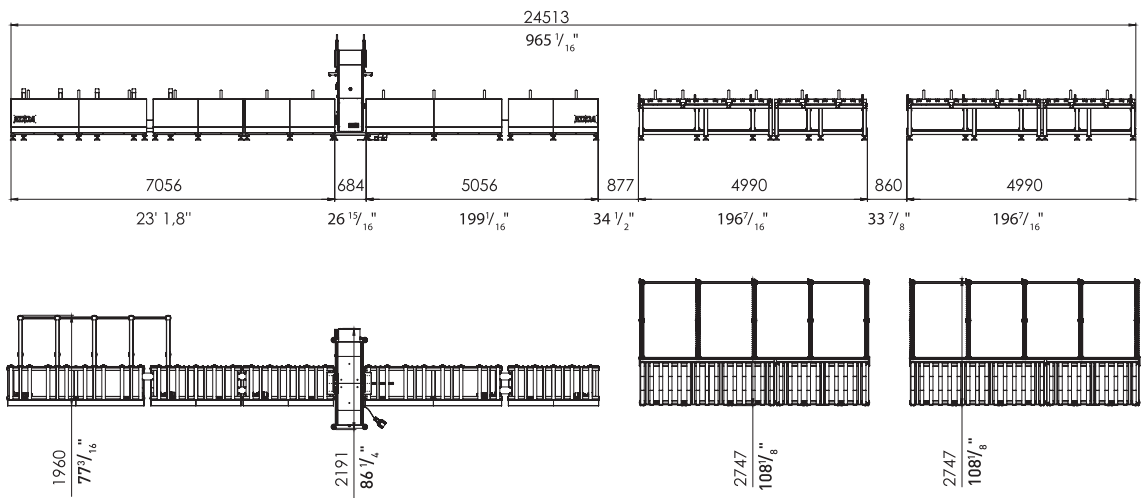
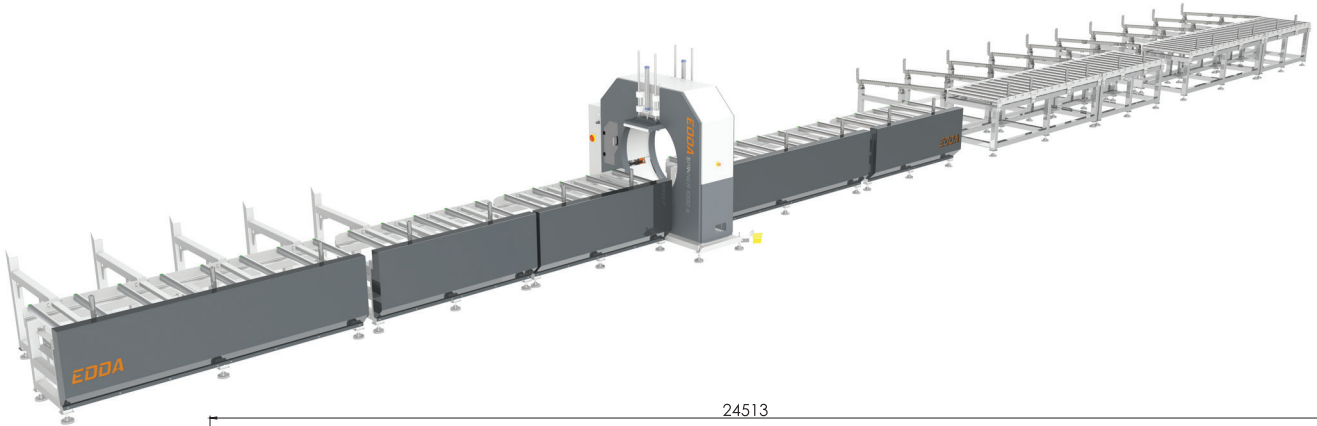

AUTOMATED LINES

TECHNICAL FEATURES

PRODUCT TO WRAP SIZES

Max. Length	mm/inch	Unlimited		
Min. Dimensions (W x H x L)	mm/inch	100 x 20 x 1400	3 15/16" x 25 1/32" x 55 1/8"	* With Short Part Nail

STRETCH FILM FEATURES

Max. Width	mm/inch	170	7 1/8"	
Max. Diameter	mm/inch	Ø230	9 1/16"	
Reel Core Diameter	mm/inch	Ø76	2 63/64"	
Recommended Thickness	micron	23, 30, 35		

MACHINE GENERAL FEATURES

Main Motor Power	kW	1,5		
Max. Ring Rotation Speed	rpm	80		
Min. Ring Rotation Speed	rpm	10		
*Electric Supply	Volt - Hz	380 Volt - 50/60 Hz - 3P+1N+1G		
Standard Machine Dimensions (W x H x L)	mm/inch	2191 x 2341 x 4271	86 17/64" x 92 11/64" x 168 5/32"	(Max. Weight: 4,5 kg)
Total Weight*	kg	*Depends to machine configuration		

CONVEYOR BELT'S FEATURES

**Please contact to Sales Representative for details