

WRAPTOR TP 1650 H:3000

PALLETS - BOXES

Ask for details

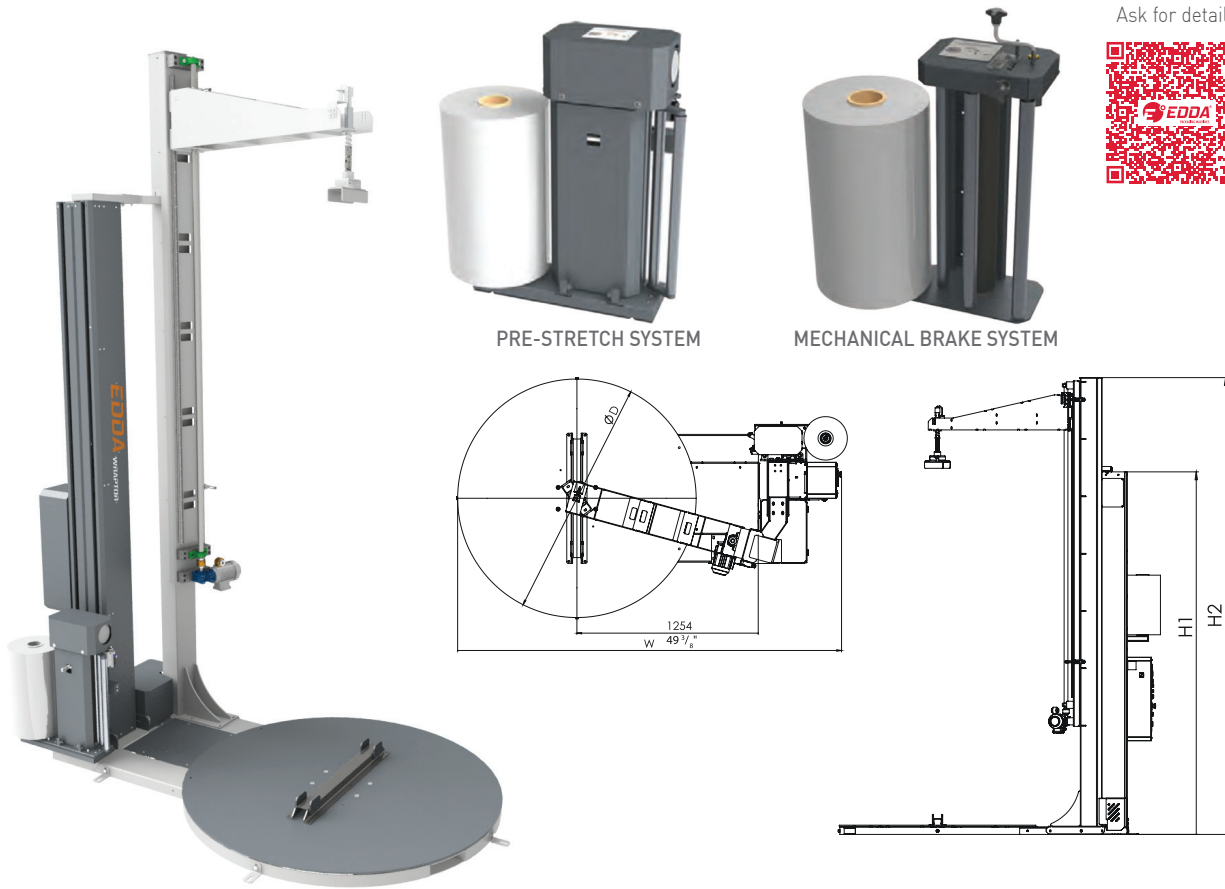

VERTICAL STRETCH FILM SERIES

TECHNICAL FEATURES

MACHINE GENERAL FEATURES

		WRAPTOR TP 1650 MB 3000	WRAPTOR TP 1650 VPT 3000
Table Diameter	mm/inch	Ø 1650 64 ⁶¹ / ₆₄ "	Ø 1650 64 ⁶¹ / ₆₄ "
Table Turning Speed	rpm	2 - 10	2 - 10
Forklift Lifting Place		Front	Front
*Electric Supply	Volt - Hz	220 Volt - 50/60 Hz Monophase	220 Volt - 50/60 Hz Monophase
Total Power	kW	1	1,2
Tensioning System		Mechanical Brake	Motorized Pre-Stretching
Tensioning Rate	[%]	0 - 100	0 - 250
Speed Adjustment		Available	Available

* 110 Volt 50/60 Hz Monophase (optional)

FILM ROLL FEATURES

Film Width	mm/inch	200 - 500 77 ¹ / ₈ " - 19 ¹¹ / ₁₆ "	200 - 500 77 ¹ / ₈ " - 19 ¹¹ / ₁₆ "
Max. Roll Diameter	mm/inch	Ø250 9 ²⁷ / ₃₂ "	Ø250 9 ²⁷ / ₃₂ "
Max. Roll Weight	kg	16	16
Roll Inner Diameter	mm/inch	Ø76 2 ⁶³ / ₆₄ "	Ø76 2 ⁶³ / ₆₄ "

PACKAGING PRODUCT DIMENSIONS

Max. Dimensions (W x D)	mm/inch	1300 x 1100 51 ³ / ₁₆ " x 43 ⁵ / ₁₆ "	1300 x 1100 51 ³ / ₁₆ " x 43 ⁵ / ₁₆ "
Max. Height	mm/inch	3000 118 ⁷ / ₆₄ "	3000 118 ⁷ / ₆₄ "
Loading Capacity	kg	2000	2000

MACHINE DIMENSIONS

Height	mm/inch	3835 150 ⁶³ / ₆₄ "	3835 150 ⁶³ / ₆₄ "
Width	mm/inch	1650 64 ⁶¹ / ₆₄ "	1650 64 ⁶¹ / ₆₄ "
Depth	mm/inch	2660 104 ²³ / ₃₂ "	2660 104 ²³ / ₃₂ "

